

# KELVA CORRUGATED CLEANER ST85CC

## DOUBLE-SIDED, NON-CONTACT WEB CLEANING



---

To remove dust and particles from wide webs in an efficient way, the new **KELVA Corrugated Cleaner ST85CC** features a very powerful airflow of both vacuum and blowing air, as well as integrated antistatic bars.

Opening and closing of the cleaner is handled by pneumatic cylinders lifting the upper part to allow access for web threading and service. The standard lifting height is 80 mm, and the upper part can be adjusted to increase/ decrease the gap between the two parts. The ST85CC is as standard equipped with a 2-step gap adjustment to allow for double wall corrugated web/ sheets.

The circulating air is connected to the cleaner through high-speed hose connections to minimize pressure drop.

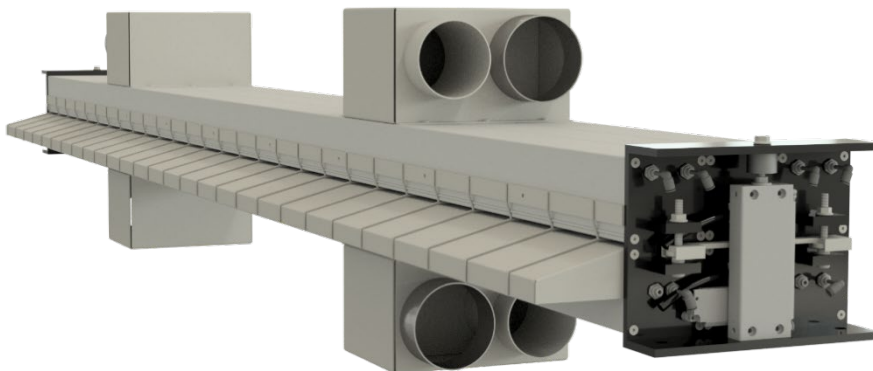

---

### Specifications

Sizes	The ST85CC is usually made to fit corrugated standard widths of 2200, 2500 and 2800 mm. Other sizes can be produced as well.
Antistatics	Integrated 230V/ 50Hz or 115V/60Hz with high voltage cables and power unit. .
Pneumatics	4-5 Bar dry, clean air. 6 mm hose connection to pressure regulator. 24VDC control valves.
Infeed and grid	Included as standard. Can be adapted to fit special requirements.

## Dimensions

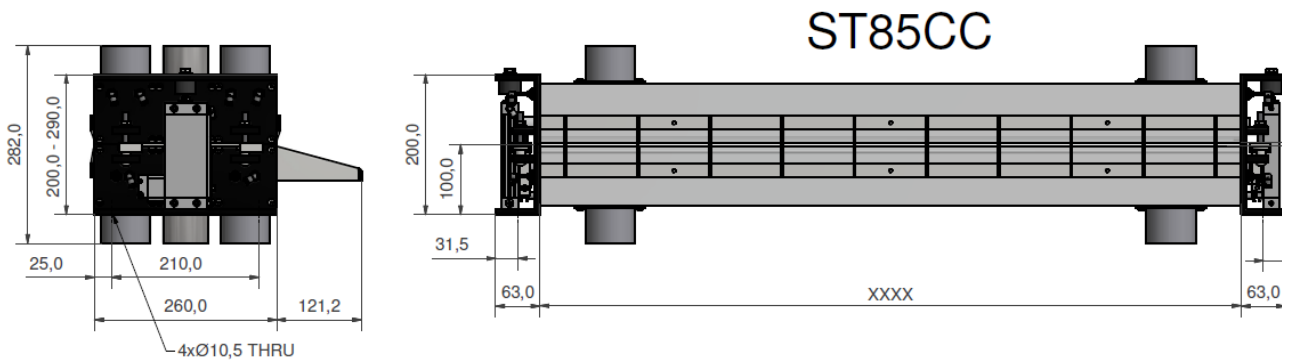

## Application and details



ST85CC installation at slitter/ scorer position



Gap adjustment, multistep cylinder



Infeed arrangement and grids

**KELVA HEAD OFFICE – SALES SWEDEN**  
 Bryggaregatan 23  
 SE-227 36 Lund  
 T +46 46 16 07 00  
 kelva@kelva.com

**KELVA OFFICE – SALES GERMANY**  
 Nürnberg  
 T +49 9128 724 11 19  
 kelva@kelva.com

**KELVA OFFICE – SALES INDIA**  
 Ahmedabad  
 T +91 848 700 88 24  
 kelva@kelva.com

**KELVA OFFICE – SALES SWITZERLAND**  
 Niederhaslistrasse 12  
 CH-8157 Dielsdorf  
 T +41 44 855 50 00  
 kelva@kelva.com

**KELVA OFFICE – SALES THE NETHERLANDS**  
 Amsterdam  
 T +31 627 07 71 77  
 kelva@kelva.com